

11-FRAME BRITISH NATIONAL BEEHIVE

CONSTRUCTION DETAILS FOR 3/4" (19mm) THICK LUMBER

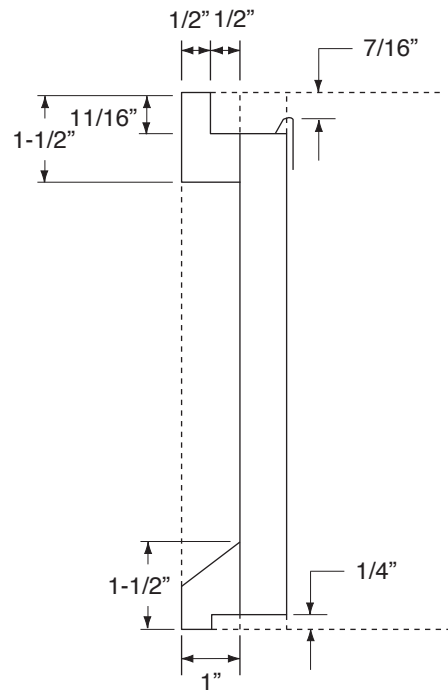
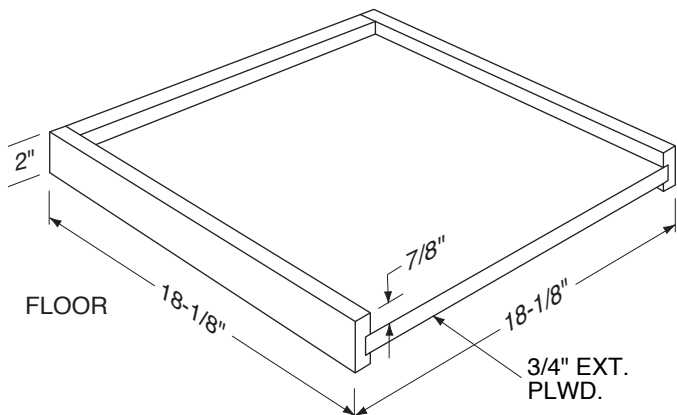
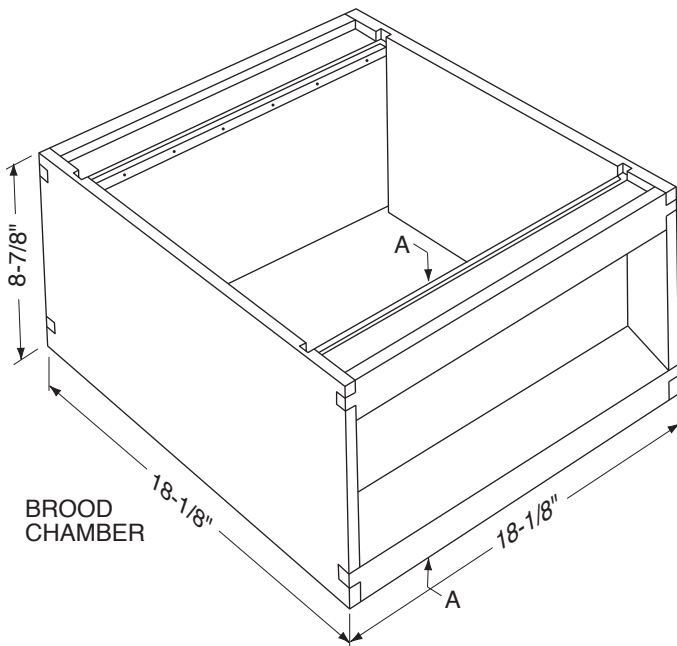
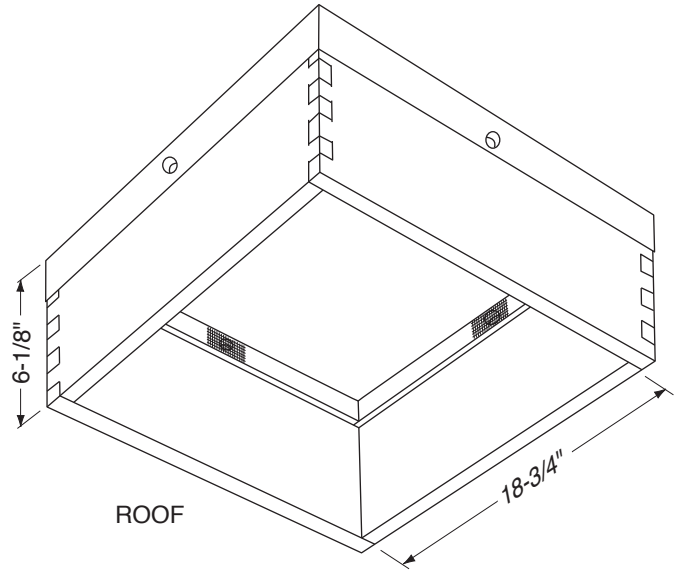
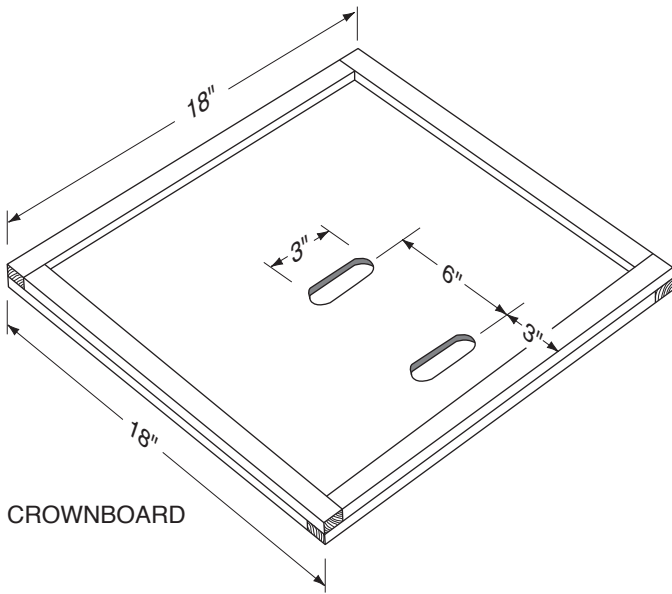

SECTION A

11-FRAME BRITISH NATIONAL BEEHIVE

CONSTRUCTION NOTES

To convert hive to top bee space:

Omit the 1/4" rabbet from the bottom cross piece, and make the rabbet on the top cross piece 15/16" deep (still leaving a 1/2" shoulder). When assembling, the bottom of the end walls fit flush with the bottom of the side walls, and the top edges of the metal runners finish up 11/16" below the top edges of the side walls.

Shallow Super:

The construction of the super is identical to that of the brood chamber, except that the overall depth is 5-7/8". Refer to the illustrations for the Brood Chamber, but note the difference in depth.

Crown Board:

Made from softwood at least 3/8" thick and with rabbeted, or tongue and groove joints, or plywood at least 1/4" thick. A bee space of 1/4" on each side by framing with four strips of wood 17-1/8" x 7/8". Arrange strips so that at any corner the joint on one face is at right angles to the corresponding corner joint on the other face (see illustration). Alternatively the board may be rabbeted into a frame so that a 1/4" bee space is provided on each side. Two openings in the board 1-1/16" x 3" adapted to receive Porter bee escapes, one centered and the other parallel to it with its center 3" from the edge of the board. Fit the edge strips to the board paying attention to the arrangement of the strips at the corners. Glue may be used - bear in mind that if the crownboard is stuck down well by the bees, it may require considerable prying from a hive tool to dislodge it.

If the board is used over a top bee space arrangement, the edge strips on the underside of the board should be omitted, otherwise the bees will build brace comb above the frames in the additional space provided if the strips are present. The strips on the upper face of the crownboard, for use when it doubles as a clearing board, should be 3/8" thick rather than 1/4".

Roof:

Inside measurement of roof is 18-3/4" x 18-3/4" x 5-3/4". Top boards should not be less than 3/8" thick, and side walls not less than 1/2" thick. Corners should be box jointed and nailed both ways. If using rabbeted joints for the corners, the lumber should not be less than 5/8" thick. Roof should be covered with non-rusting metal or other waterproof material extending at least 1-1/2" down the side. Attach four wooden strips each 18" long and 1-1/4" x 3/4" cross section, fitted round the top inside to give a head space of 1-1/4" above the crown board. Drill ventilation holes 3/4" diameter centered through the sides of the roof and spacing strips, and backed non-rusting wire mesh. Assemble the four sides of the roof, taking care to nail the corners in both directions, then fit the top boards, nailing them through onto the side boards along all four sides. Next fit the four strips to provide the head space, then cover with waterproof cover before completing the ventilation holes.